

## Summary for the final report

### Commissioning of learning controllers on the example of the complex process chain with additional moisturization module for 3D-forming of paperboard cups (Commissioning of Intelligent Production Systems)

---

Intelligent manufacturing meets sustainable packaging → Imagine a paperboard cup is being formed while an intelligent controls system predicts quality and optimizes each production step in real time. By optimizing process parameters under varying material and environmental conditions, this approach ensures stable and intelligent production. Building on this idea, the project successfully demonstrated the efficient manufacturing of sustainable packaging under real-world conditions.

A joint project between Fraunhofer IWU and TU Dresden developed a transferable concept that uses a powerful combination of digital twins and machine learning (ML) to make the production of paper cup manufacturing more efficient and intelligent. In contrast to traditional metal forming, the 3D-forming of paper cups poses a particular challenge. Wrinkling during forming is characteristic of paperboard's deep drawing, as the material can only be redistributed to a limited extent in the sheet plane. Wrinkles are therefore not avoided but specifically controlled to achieve the desired cup shape and stability. We were able to confirm that key parameters such as blank holder force, temperature, and material moisture have significant influence on the forming process. To achieve faster cycle times and to combine several processing steps, the cups are formed directly from the paperboard web and then separated in the final step [see Fig 1].

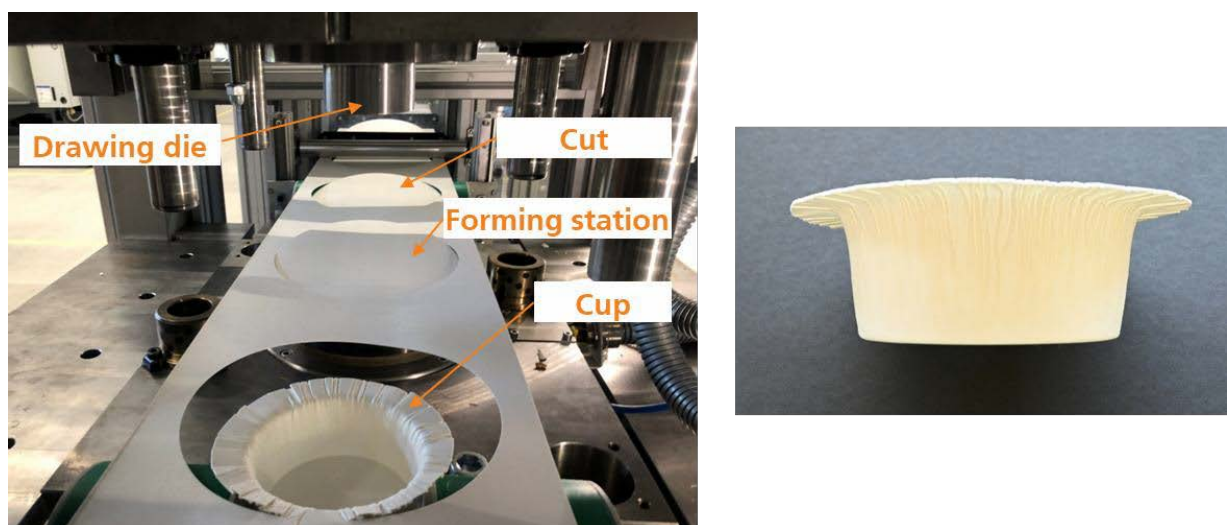

Fig 1: Left: Cup forming from the cardboard web, right: Cardboard cups as a sustainable packaging solution

The development of an intelligent control system for paper cup production began with data generation [Fig 2]. A detailed finite element simulation (FE) was developed to represent the entire forming process. Particular focus is placed on the precise modeling of wrinkle formation. This posed a numerical challenge in terms of stability and accuracy. The FE-simulation was calibrated using experimental data from laboratory tests to reliably cover cup quality and process limits. However, due to the high computational intensity, this simulation was not suitable for real-time predictions at a production rate of up to 60 strokes per minute. Therefore, as a second step, a Technology Controls Model (TCM) was developed that uses machine learning to reproduce the behavior of the simulation. It predicts the crease distribution based on the current state of the cardboard and the process parameters. After successful training, the TCM was integrated into a digital twin for virtual commissioning (for virtual process visualization & validation) and then transferred to the real control system. For each production hub, TCM calculates a quality forecast to ensure that the wrinkle distribution remains within predefined tolerances. In the production environment, an algorithm automatically analyzes images of the molded cups to check quality. The result is an intelligent control system capable of ensuring stable production under varying material and environmental conditions.

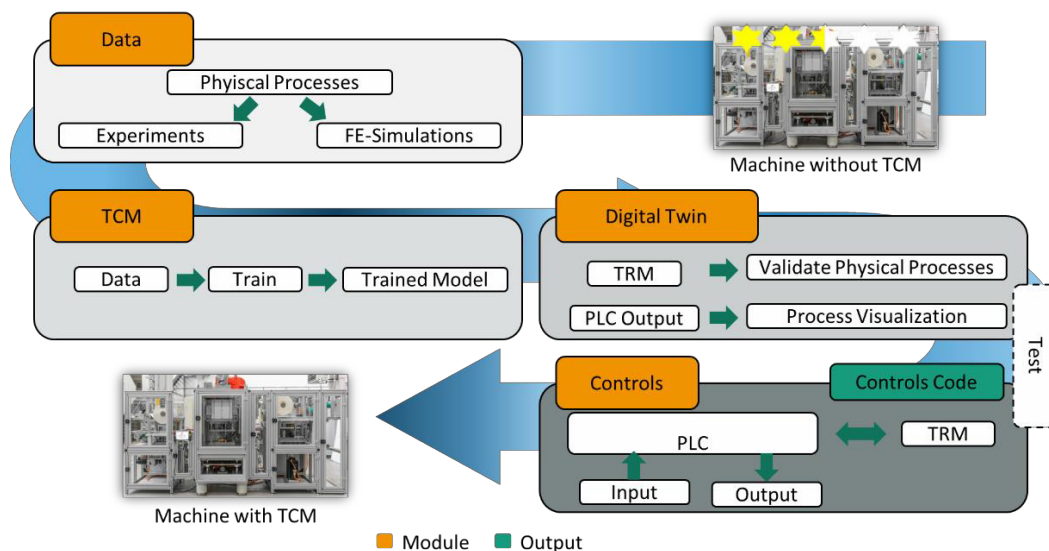

Fig 2: Process Overview

IVLV members can download the complete final German project report from our homepage. All you need is to register in the section "[My IVLV](#)". Non-members can request the final report from the IVLV office at [office@ivlv.org](mailto:office@ivlv.org).



Gefördert durch:



aufgrund eines Beschlusses  
des Deutschen Bundestages

The IGF project 01IF22573N was funded by the Federal Ministry of Economics and Energy based on a resolution of the German Bundestag.